



### Features

Simple design with metal parts encapsulated in high grade natural rubber compound giving good environmental resistance.

Provides relatively large static deflections and hence a high degree of vibration attenuation - 90% isolation for disturbing frequencies of 15 Hz ( 900 c.p.m ).

Range gives capacity for point loads of 35 kg to 350 kg.

### Metalastik® type Fanflex™

A simple mounting designed predominantly for the suspension of heating, ventilating and air conditioning equipment.

May be used for:

Pumps, fans, compressors and control cabinets.

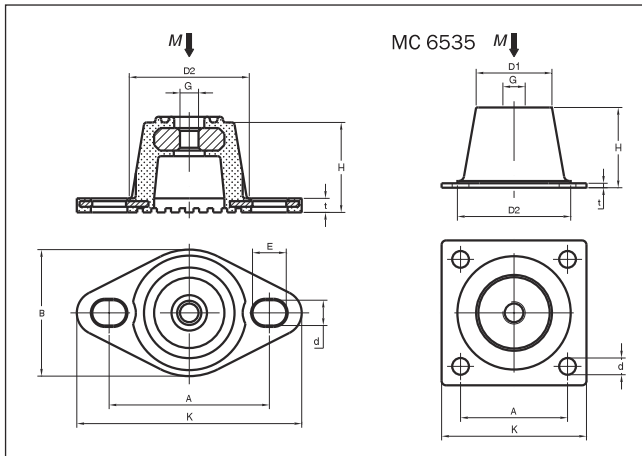

Type	Drawing no.	Part no.	Dimensions in mm										Weight (Kg)	M-Max (Kg)	Colour Code
			A	K	H	B	D1	D2	E	G	d	t			
Fanflex 100-45	19-0200	20-00518	57	80	32	45		41	12	M8	9	5	0,09	35	yellow
Fanflex 100-55	19-0200	20-00519	57	80	32	45		41	12	M8	9	5	0,09	65	blue
Fanflex 100-65	19-0200	20-00520	57	80	32	45		41	12	M8	9	5	0,09	100	red
Fanflex 200-45	19-0201	20-00521	71	95	45	60		56	14	M10	9	5	0,22	130	yellow
Fanflex 200-55	19-0201	20-00522	71	95	45	60		56	14	M10	9	5	0,22	225	blue
Fanflex 200-65	19-0201	20-00523	71	95	45	60		56	14	M10	9	5	0,22	350	red
MC 6535-45	19-0565	20-00662	48	65	36		34	51	8	M10	7,5	2	0,12	45	white
MC 6535-55	19-0565	20-00663	48	65	36		34	51	8	M10	7,5	2	0,12	75	red
MC 6535-65	19-0565	20-00664	48	65	36		34	51	8	M10	7,5	2	0,12	115	black

Note: The natural frequencies and degrees of isolation are based on dynamic characteristics of the mountings.

Load per mounting (kg)

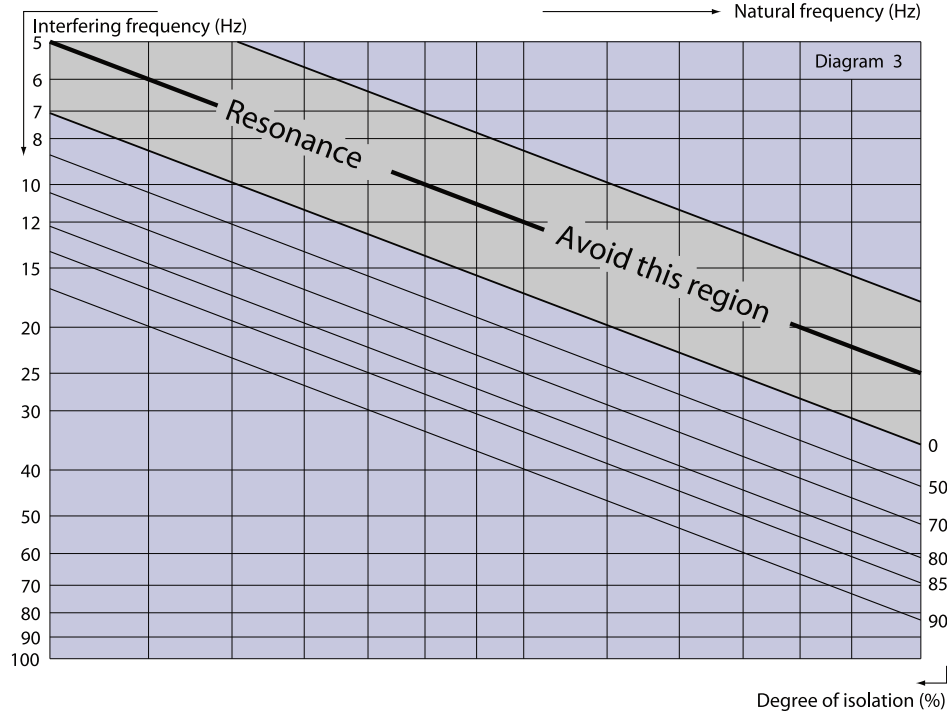
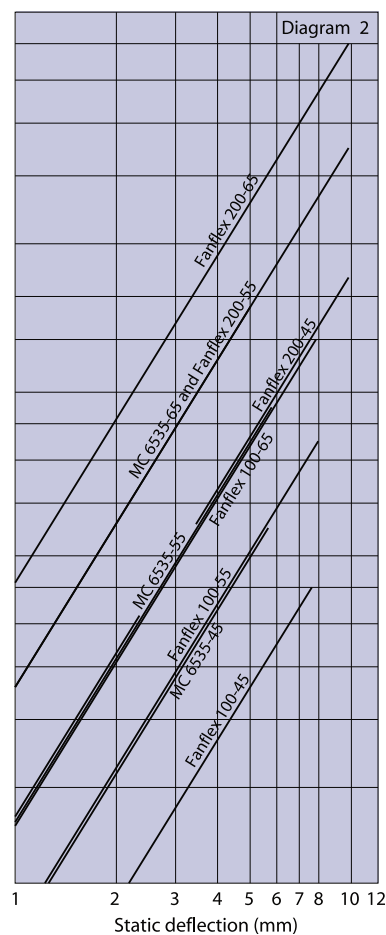
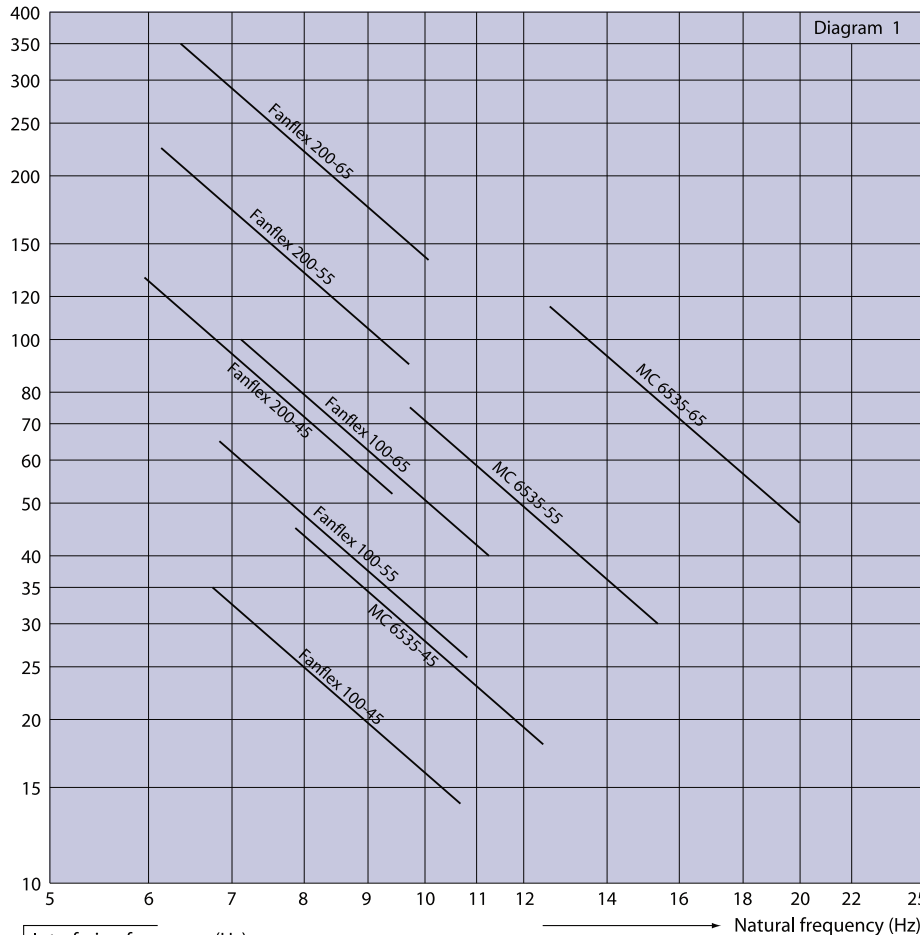

To select correct mounting, following data are needed:  
 1) Load per mounting (kg)  
 2) Interfering frequency (Hz)  
 (Hz = rpm / 60)  
 Select correct load line in diagram 1 and correct interference line in diagram 3. The load line intersects with required type of mounting.  
 Connect this intersection point vertically down to the interference line in diagram 3. Here, on the sloping curve, the isolation degree is indicated.  
 For static deflection, see diagram 2.

